

LRF059-0035



OVERVIEW

The compact, eye safe and highly integrated oem laser rangefinder module is utilized in various applications from versatile systems to handheld devices. The module is delivered without enclosure enabling OEM-users to embed the module into their own system or device. rangefinder laser distance sensor With TTL Output a new generation ranging sensor with optimally-designed emitting & receiving optical lens, suitable for precise, long-distance measurements. It provides accurate distance measurement whatever the target color and reflectivity unlike conventional technologies. Can measure absolute distances up to 3500m on a white target, setting a new benchmark in ranging performance levels, opening the door to various new applications. Rangefinder laser distance sensor module offers reliable distance feedback & TTL/RS232 serial output. It is suitable for customizing product integration, especially for night vision, thermal or EVA, ect.



TECHNICAL SPECIFICATIONS

Parameters	Specification
Laser wavelength	905nm
Dimensions(mm)	60.56*33.1*46.86mm
Range capability	5-3800m (typical value) 5-3000m from woods
Resolution	±0.1m
Working current	80mA-123mA
Connector	RS232 / TTL /485
Operating Temperature	-20° ~ 55°
Signal	RS232 output/TTL output/485output
Input voltage	3~5V
Divergence	5 mrad
Repetition Frequency(RF)	1Hz
Power	<1mW (eye-safe)
Ranging method	pulse mode
Weight	<40g



MECHICAL INTERFACE

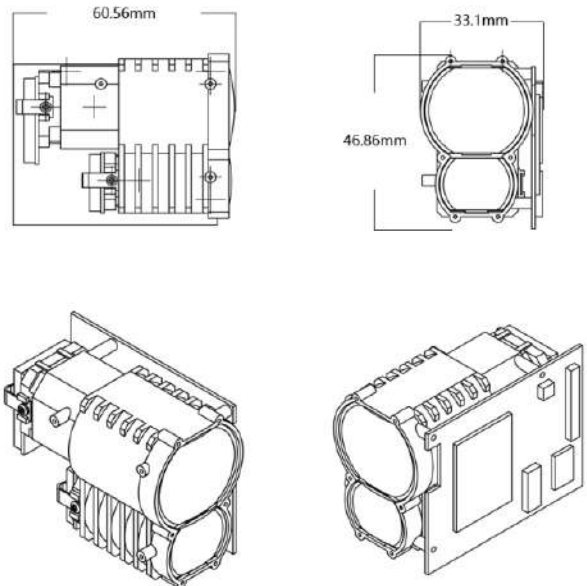

COMMUNICATION INTERFACE

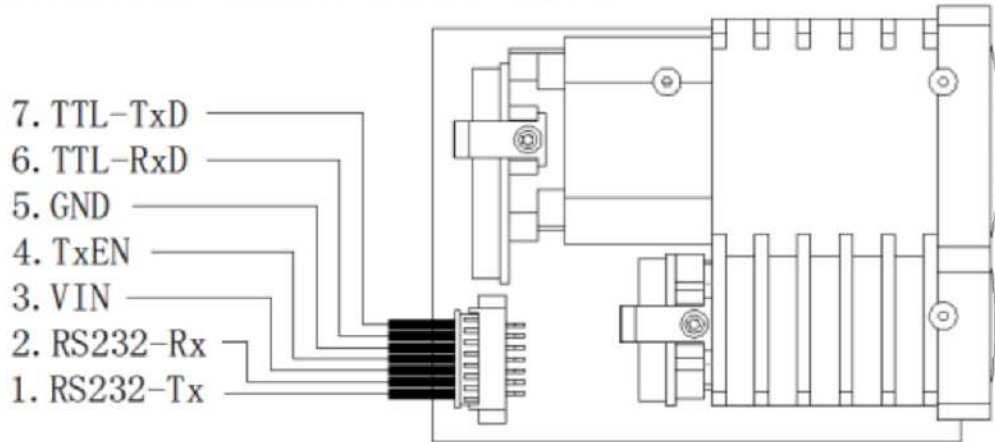

Pin No.	Function description
1	RS232-Tx
2	RS232-Rx
3	Power supply: DC (3.0V - 5.0V)
4	TxEN: When serial port starts to send data frame, TxEN signal is high; After one frame data transmission is over, TxEN signal is low. TxEN Signal can be used to switch from emission to reception as half duplex, such as RS485.
5	GND
6	UART-RxD (TTL: Voltage is programmable: 3.0V - 5.0V) ;
7	UART-TxD (TTL: Voltage is programmable: 3.0V - 5.0V);

Note:

- This module has 2 communication serial output, RS232 & TTL. Each can be used by different pin outs, but can't be used at the same time.**
- UART Setting: 10 bits are transmitted or received; one start bit, 8 data bits (LSB first), one stop bit, non-parity**

Electrical Characteristics

Parameter	Test condition	Min	Max	Units
Vin	T=25°C	2.5	5.0	V
Icc	Standby(T=25°C, Vin=3.0V)	-	50.0	mA
	Ranging(T=25°C, Vin=3.0V)	-	150.0	mA

COMMUNICATION COMMAND CHART

Master Command

Command code	Description	Broadcast add. response
0x80	Read rangefinder status	NO
0x81	Read measuring result	NO
0x83	Start ranging	NO
0x84	Stop ranging	NO

0x9E	Communication parameter program	YES
0xBE	Read communication parameter	YES
0xC0	Communication test	YES
0xC1	Read Firmware Version	YES
0x8F	Red Laser ON / OFF	YES
Slave Response		
Recognition code	Description	
0x60	Simple reponse Frame	
0x01	Range data frame	
0x20	rangefinder status frame	
0x21	Communication parameter frame	
0xE0	Error message frame	

NOTE:

1. The Communication Frame Format:

SlaveID + instruction + parameter +checksum

2. The interval between two adjacent frames has to be at least the time of 1.5 byte when sent out, when it is less than 1ms, it is regarded as 1ms;

600BPS: 25ms

1200BPS: 12.5ms

2400BPS: 6.25ms

4800BPS: 3.125ms

9600BPS: 1.56ms

19200BPS: 1ms(0.78ms < 1ms, take 1ms)

3. Sending calculate of checksum;

This module uses the verification mode of byte by byte accumulation sum, SlaveID is not included in the verification, sending checksum at last.

Such as calculate check sum of scanning mode instruction"0x83 0x40":

A、 Calculate accumulation sum : $0x83 + 0x40 = 0xC3$;

B、 Take LSB[D7..D0]: $0xC3$;

C、 Calculate 2's complement: $0x100 - 0xC3 = 0x3D$, $0x3D$ is checksum;

Add slave address when mater sends: $0x10\ 0x83\ 0x40\ 0x3D$

4. Verification receipt;

Such as receive communication frame: $0x10\ 0x83\ 0x40\ 0x3D$, verification not including slave address $0x10$

A、 Calculate accumulation sum : $0x83 + 0x40 + 0x3D = 0x100$;

B、 Take LSB of accumulation sum: $0x00$; $0x00$ is verification result;

If verification result is $0x00$, that means received data is right; If verification result is not $0x00$, that means received data is wrong.



Note:In the example, the slave address of each command is $0x10$;in application, the slave address will be the

programmed one.

1、Communication test (0xC0)

Master sends		
Command code	Parameter	Description
0xC0	None	
Slave responses		
Recognition code	Parameter	Description
0x60	None	
Example		
Master sends: 0x10 0xC0 0x40; 0x40 is checksum		
Slave response: 0x10 0x60 0xA0; 0xA0 is checksum		

2、Command slave to start ranging (0x83)

Master sends		
Command code	Parameter	Description
0x83	byte1	D7: Reserve
		D6: Continuous ranging mode, 0 = off; 1 = on;
		D5: Fog mode, 0 = off; 1 = on;
		D4: Data unit, 0 = meter; 1 = yard;
		D3 - D0: Working Mode, 0 = ranging; 1 = speed; 2 = Small Target Mode ;
Slave responses		
Recognition code	Parameter	Description
0x60	None	If slave is set as automatic export mode, slave responds 0x60 first after reception of start ranging command, after ranging is finished, it will then send out ranging result;
Example		
Master sends:		
0x10 0x83 0x00 0x7D: Mode 0 is for single measure, data unit is meter;		
0x10 0x83 0x40 0x3D: Mode 0 is for continuous measure, data unit is meter;		
0x10 0x83 0x10 0x6D: Mode 0 is for single measure, data unit is yard;		
0x10 0x83 0x20 0x2D: Mode 0 is for continuous measure, data unit is yard;		
Slave response:		
0x10 0x60 0xA0		

Note: 1、 If module data export method is set as **query mode**, then it can only do single measure;

2、 In **speed mode**, continuous ranging function is null, that is no continuous speed measure;

3、 Fog mode is only valid for device with fog mode function;

4、 Slave will send 0x60 response frame after reception of start ranging command, it will start to send ranging result after ranging is finished.

5、 Small Target Mode was supported only in V7.00 or newer version;

3、Command slave stop ranging(0x84)

Master sends		
Command code	Parameter	Description
0x84	None	

Note: After master sends command to slave to do continuous ranging, it needs to send this command to slave to stop ranging. If master sends command to slave to do single time ranging, then no need to send this command, cause slave will stop ranging automatically after ranging is finished.

4、reading slave status(0x80)

Master sends		
Command code	Parameter	Description
0x80	None	
Slave responses		
Recognition code	Parameter	Description
0x20	byte1	D7: 1 = Busy; 0 = Ranging finished, Master can read result; D6: 1 = Module has some error; D5 - D2: Reserve; D1: 1 = Angle sensor enabled; D0: 1 = Angle sensor has some error;
	byte2	Reserve

5. Read range finder result(0x81)

Master sends		
Command code	Parameter	Description
0x81	None	
Slave responses		
Recognition code	Parameter	Description
0x01	byte1	D7: 1 = Distance is invalid; D6: 1 = Angle is invalid; D5: Data resolution, 0 = 0.5/LSB; 1 = 0.1/LSB; D4: Data unit, 0 = meter; 1 = yard; D3 - D0: Working Mode, 0 = Ranging; 1 = Speed;
	byte2	When distance is valid: Distance[D15..D8]; When distance is invalid: 0x80 = Ranging no result; 0x81= System error;
	byte3	When angle is valid: Distance[D7..D0]; When angle is invalid: Reserve;
	byte4	Angle[D7..D0]: Data is 2's complement format; When measuring speed, not sending angle data;

Example

- slave sends distance frame: 0x10 0x01 0x20 0x12 0xD7 0xFE 0xF8
distance value = 0x12D7 = 4823 = 482.3m
angle vlaue = 0xFE = -2°
- slave sends speed frame: 0x10 0x01 0x21 0x03 0xD7 0x04
speed value = 0x03D7 = 983 = 98.3km/h
- slave sends distance frame: 0x10 0x01 0xA0 0x80 0x00 0x01 0xDE
distance value null (First byte is 0xA0, D7 = 1)
angle value = 0x01 = +1°

6. Write slave communication baud rate(0x9E)

Master sends		
Command code	Parameter	Description
0x9E	byte1	has to be 0x90
	byte2	Reserve
	byte3	Reserve

	byte4	UART IO voltage Setting: 72 - 199, 0.025V/LSB;
Slave responses		
Recognition code	Parameter	Description
(please refer to the slave respons part of reading slave parameter)		
Example		
Change UART IO voltage to 3.3V, then master sends: 0x10 0x9E 0x93 0x00 0x00 0x84 0x4B		

Note: VIO = Setting * 0.025V, Default VIO = 3.3V

10、Reading communication parameter (0xBE)

Master sends		
Command code	Parameter	Description
0xBE	byte1	Must be 0x91 or 0x92
Slave responses		
Recognition code	Parameter	Description
0x21	byte1	Slave address: 0x01 - 0xFF
	byte2	D4: Data export method ; D3 - D0: Baud Rate setting;
	byte3	UART IO voltage setting

11、Slave sends wrong information (0xE0)

Slave responses		
Recognition code	Parameter	Description
0xE0	byte1	D7 - D3: Reserve; D2: 1 = Communication parameter error; D1: 1 = Unrecognizable command; D0: 1 = Checksum error;

12、Red Laser On/Off (0x8F)

Master Sends		
Command Code	Parameter	Description
0x8F	byte1	0x00: Red laser OFF; 0x01: Red laser ON;

13、Read Firmware Version(This command was supported only in V7.00 or newer version)

Master Sends		
Command Code	Parameter	Description
0xC1	There is no	
Slave responses		
Recognition code	Parameter	Make clear
0x61	Byte 0	Major Version(BCD)
	Byte 1	Minor Version(BCD)
Example		
Slave responses: 0x10 0x61 0x07 0x00 0x98		
Data "0x07 0x00" means firmware version is V7.00.		

Revision No.	Description
V1.0	1.First Revision;
V1.1	1.Added Command: Set UART IO voltage;
V2.0	1.Added Command: Red Laser ON / OFF
V3.0	1.Revise some bug;
V4.0	1.Added Command: Read Firmware Version; 2.Added Small Target Mode;